



A NEW PERSPECTIVE



Pricing Guide  
January 2009

## CONTENTS

<b>FORWARD</b>	3
• ORDERING INFORMATION	3
• MATERIALS	5
• CARE AND MAINTENANCE	6
<b>AERO DESIGN CONCEPT</b>	7
• DESIGN TEAM	7
• WOOD SPECIES & FINISHES	8
• FEATURES & BENEFITS	9
– OVERALL COLLECTION	9
– CONFERENCE TABLES	10
– MEDIA UNITS	11
– WIRE MANAGEMENT	12
<b>CONFERENCE TABLES</b>	13
• SQUARE TABLES	14
• RECTANGLE TABLES	15
• VIDEO CONFERENCING TABLES	20
• CONFERENCE COMPLIMENTS	29
<b>MEDIA UNITS</b>	25
• STANDARD HEIGHT CREDENZA	26
• 20" H CREDENZA	27
• MEDIA UNIT OPTIONAL DETAILS	28
<b>BUFFET CREDENZAS</b>	29
<b>CONFERENCE COMPLIMENTS</b>	31
• HOSPITALITY CART	32
• HOSPITALITY TABLE	32
• LECTERN	32
• MEDIA BOARDS	32
• BOOKCASES	33



## ORDERING INFORMATION

### Orders

All orders must be complete and in writing to avoid error or duplication. Review this Ordering Guide to ensure necessary information is included on your purchase. Omission of pertinent information may cause delays in production of your order.

### Acceptance

Order acceptance is contingent upon credit approval. Accepted orders will be acknowledged with a CCN Acknowledgement Form; this document is final and binding. CCN International is not responsible for any misinterpretation unless notification is made to CCN within 10 days after order acceptance. CCN attempts to clarify all purchase orders. In the event the catalog number and description differ, the catalog number will prevail. It is the customer's responsibility to check the Acknowledgement Form for errors. If a specific date is required for delivery, please indicate on your purchase order and we do our best to accommodate your request. All acknowledgements contain an estimated shipping date. Buyer may be held liable for storage charges if not ready to receive goods when orders are completed.

### Prices

Customer agrees to pay for all items ordered from CCN in accordance with the published price list in effect at the date of order acceptance, or in the case of modified product, the factory quote. For quoted products, please include CCN quote number on your purchase order. Prices and specifications are subject to change without notice.

### Terms and Discounts

Standard terms of sale for CCN are net thirty (30) days from date of invoice. All prices are quoted F.O.B. factory. Dealer discounts in effect between CCN and authorized CCN dealers will be honored from list price unless another agreement between both parties has been made. Finance charges will be assessed on overdue balances.

### Deposit

CCN typically requests a minimum deposit of 50% prior to commencement or shipment of merchandise. CCN will request the exact amount required and the date due in writing. If you have been notified that a deposit is required, production will cease if deposit is not received by specified date. Your responsiveness to deposit requests may affect your lead-time.

### Specifications

CCN International's ongoing product improvement program may result in changes in design, construction, or discontinued products without notice.

### Changes and Cancellations

Any order changes or requests for cancellation after receipt of the CCN order acknowledgement are subject to our ability to conform and will be subject to a charge for our expense of materials, labor or other costs incurred by CCN, depending on the status of the order at the time of the change or cancellation request.

### Return Goods Authorization

CCN will not accept the return of merchandise for any reason, without prior approval from CCN Management and Customer Service Department. Unauthorized returns will be refused.



## **ORDERING INFORMATION** (cont..)

### **Shipping**

CCN International orders will be shipped freight collect, bill third party or prepaid and added to the invoice. Shipments will be made “best way” unless a carrier has been specified by the purchaser. Large items such as reception desks must be shipped by a blanket wrapped carrier. All orders are shipped F.O.B. factory. Customer bears risk of loss or damage during shipment. We will make every attempt to ship orders complete and on schedule; however CCN reserves the right to make partial shipments. If a customer requests postponement of delivery after production has begun, CCN reserves the right to transfer furniture to storage at the customer’s own risk and expense or assess storage charges for furniture stored at CCN if space is available. Such transfer or storage shall be deemed delivery to customer for all applicable invoicing and payment. Specific delivery dates and times cannot be guaranteed. However, CCN recognizes the importance of coordinating delivery and installation and will forward requests to the trucking company. Under no circumstances will CCN or the trucking company be held responsible for any costs incurred due to late delivery.

### **Freight Damage and Claims**

CCN is not liable for damage to furniture during transit or storage. Each shipment is packed by expert packers and responsibility for loss or damage lies with the carrier. Acceptance of the shipment from CCN acknowledges that all articles were packed properly and delivered in excellent condition. If concealed damage is discovered after unpacking merchandise notify the CCN immediately. Do not destroy packing materials until the shipment has been inspected. CCN suggest the words “subject to inspection” accompany the signature if the goods are curtailed, and cannot be examined at the time of receipt. Please do not refuse any shipment, since by doing so you abandon all rights to the shipment. In all cases, the burden of proof for liability rests with the claimant. Good receiving practices and proper inspection of goods at the time of

CCN International orders will be shipped freight delivery for all shipments will help to ensure all bona fide claims are collected from the transportation companies.

### **Warranty**

CCN International warrants its furniture to be free from defects in material and workmanship under normal use and service for a period of one year from the date of shipment. During this warranty period, CCN International’s obligation is limited only to the repair, or at its discretion, the replacement of such furniture which, upon return to factory or upon examination, proves to be defective. Any damages incurred during transit or damages incurred by the customer are not applicable under this warranty. CCN International makes no other warranty, either expressed or implied, including without limitation the product’s condition, its merchantability, or its fitness for any particular use or purpose.

# MATERIALS

## Wood Products

All pieces are built with 45 lb. per cubic foot density engineered composite board, faced with quartersawn, rift cut, or plain sliced veneer. Painted components are built with medium density fiberboard. Exterior faces are premium grade veneer with specific veneer piece count determined by the width of the panel. Exposed edges are core banded with solid wood. The solid wood moisture at the time of application is between 6% and 8%.

## Hardware used to build CCN Products

All case goods are equipped with adjustable levelling glides to assure level set-up and protection of floor coverings. All pieces are constructed square to sit level on flat surfaces. Hinged doors have fully concealed 3-way adjustable hinges. Doors with exposed hardware or bottom edge access have magnetic catch. Doors without pulls use a touch latch to open. Access panels are mounted using clips with bolts to hold in place.

## Construction of CCN Products

All case goods are glued and clamped with dowels or compressed splines. Pedestals and modesty panels are secured with screws and reinforced with glue cleats. Metal connectors are used in conjunction with type A screws where a knockdown joint is necessary. Any exposed undersides of panels or surfaces are sprayed with a high solids sealer to improve stability of the item under varying climate conditions.

## CARE AND MAINTENANCE

Certain precautions will preserve the beauty of your new wood furniture. High or low humidity extremes can cause warping, cupping, veneer checking, and joint separation. CCN will not be responsible for the humidity controlled care of the item once it leaves the factory.

Wet objects should be placed on coasters and writing should be done on a desk pad. Sharp metal objects such as keys, spring binders, and briefcase hinges should be kept from direct contact with the furniture. Bottoms of decorative items, such as flower vases and desk accessories should also be protected.

Contact between finish and certain plastic compounds may result in discoloration and finish damage. CCN recommends the use of felt pads under plastic telephones or other business machines feet to protect the finish.

Dust build-up, may scratch or dull the surface if not removed correctly. Simply wipe the surface with a cloth dampened with a mild detergent and dry with a soft towel. Avoid the use of ammonia based products, polish containing wax or silicone oils as they may cause damage if used over a long period of time. The finish is durable and resistant to most ordinary spills. However, spills should be wiped up promptly to avoid potential problems. Fingerprints, smoking residue, and other substances may accumulate on any finished surface. None of these contaminants will harm our finish, but they should be periodically removed to restore the finish to its original luster. Just wipe the surface with a cloth dampened with a non-wax containing polish or mild detergent solutions.

### Anticipation of Color Change

All wood is photosensitive and changes color over time. This natural change occurs depending on the initial color of the wood and is especially apparent with lighter finishes. Some woods may change dramatically with exposure to direct sunlight. When ordering additional pieces for an existing installation, it is advisable to submit a finish sample with your order.

## DESIGN TEAM

### Qdesign - CHICAGO, IL

Founded in 1994 by Mark Stenftenagel and Sal Graziano, Qdesign is the product design subsidiary of Whitney Inc., a full service architectural and interior design firm with over 70 combined years of experience.

Vision... Seeing the future while looking to the past.

Passion... Bringing enthusiasm and dedication to each design challenge.

Connection... Embodying clients' goals through collaboration and innovation.

Curiosity... Asking the questions that lead to enduring design solutions.

### DESIGN INSPIRATION & GOALS

Minimalist

Purity of Form

Illusion of Super Thin Top

Full Power & Data Capabilities

Two-Tone Finish

Aesthetically Simple, Structurally Complex

Mixed Materials

## Wood Species & Finishes

### AERO FINISH PROGRAM

Part of AERO's unique aesthetic lies in the finish combinations. High-quality wood finishes are combined with painted surfaces. These color combinations can be selected to blend, or contrast offering unique design options and aesthetics.

### PREMIUM WOOD VENEERS

- Plain Sliced Maple
- Plain Sliced Cherry
- Quarter Sawn Maple \*
- Quarter Sawn Cherry \*
- Rift Cut Oak \*

\* *Horizontal grain pattern.*

Rift and Quarter Sawn veneer will have a horizontal grain direction. Plain sliced veneers have a vertical grain. The wood species listed above are finished with any of the standard CCN standard colors. For more information visit [www.ccnintl.com/FINISHES](http://www.ccnintl.com/FINISHES).

### FINISHES

#### - Standard Wood Finishes

Our finish program is represented using a number system from the lightest (#2 clear) to the darkest (#8 dark brown). These standard shades compliment the various species in a variety of ways thus creating a broad pallet.

#### - Mica Colors

CCN new solid color finishes offer a lush contrast when paired with our high-quality veneers. The top coat contains Mica flake that responds to light, lending a pearlescent quality to light colors and a metallic sparkle to the darker shades.

### HARDWARE & DETAILS

#### - Metal Accents

AERO's mixed materials design features metal accent options on the base and feet of the furniture. Polished stainless steel or aluminum powder coat are standard options, while four additional powder coat colors are available for metal components.

### METAL FINISHES

#### STANDARDS

- Polished Stainless Steel \*
- Aluminum Powder Coat

\* *Note: Casework bottom reveal and hardware are polished chrome, while foot is stainless steel.*

#### UPGRADE POWDER COAT COLORS

(Contact the factory for current powder pricing)

- Bronze
- Chrome
- Champagne
- Black

#### - Hardware

Pulls are available in polished chrome steel or powder coat to match base detail.

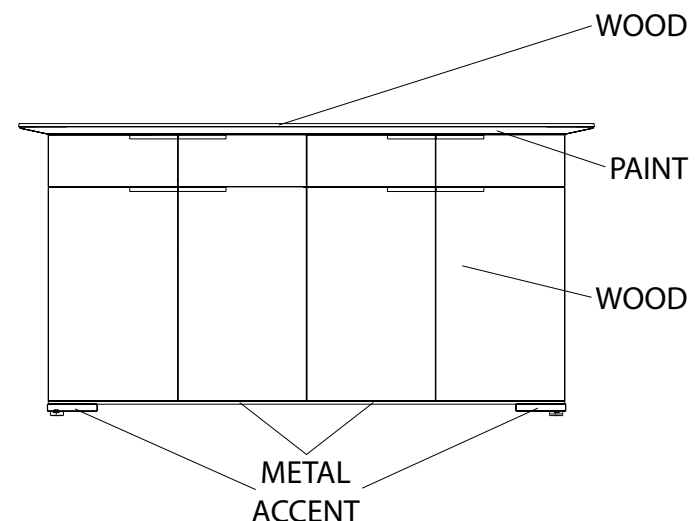
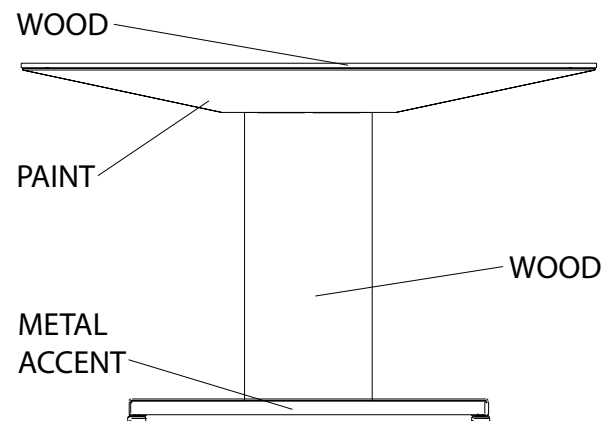

## FEATURES & BENEFITS

### AERO Series

#### – Light in Scale

The AERO tables' low-profile top and chamfered substructure provides a slim and sleek appearance. This aesthetic compliments current design trends for lighter scale and strong lines in the office environment.

#### – DuoTone Finish

AERO offers the designer new dimensions of creativity. Contrast or blend mica paint colors with our high-quality, transparent wood finishes. These additional surfaces provide a broad pallet and unique aesthetic.

#### – Core-Banded Top

Clean appearance with the edge protection and strength of solid wood.

#### – Metal Accent Details

Contrasting metal feet and bases add flair and strength to the overall design. Polished stainless steel or aluminum powder coat are standard. In addition 4 powder coat colors are available at an up charge (See page 8).

#### – Collection of Items

The AERO Series has all the elements needed for the conference room environment. Complimentary pieces, create a seamless visual aesthetic and optimize function with a breadth of media, hospitality, and storage solutions for any conference environment.



## FEATURES & BENEFITS

### Conference Tables

#### – Monocoque Construction

This construction technique supports the structural load by using the external skin. AERO's strength comes from its unitized shell construction. Thus, the entire table acts as a unit, distributing the load across of its members.

#### – Full Angular Sub-Top

Conceals entire wire management trough and structural elements.

#### – Panel Base Design

Provides minimal appearance with convenient access to wiring. Bases can be rotated 180° to accommodate wiring access that originates outside of the bases.

#### – Mixed Material Construction

Possesses the strength of steel and the beauty of wood. The use of a steel sub-frame amplifies the strength of the wood components within AERO to give the series exceptional rigidity.

#### – Component Construction

AERO is broken up into components to help streamline the installation process. The bases and trough are mechanically fastened for a quick set up for the wiring of power and data. The table top is self aligning, thus, reducing possibilities of human error during the installation process.

#### – Ease of Access

AERO allows for unobstructed power and data installation. Installers are able to work within the bases and trough without having to crawl underneath or on top of the table. Thus, increasing the speed and ease of installation, while reducing the potential for damaging the finished product. Access panels and trough are easily wired after installation as well.

#### – Matching Wood Doors

Utilizing CCN's unique veneer capabilities adds to the clean design by creating a sleek matched voice, power, and data access doors.



## FEATURES & BENEFITS

### Media Centers

#### – Media Walls/Units

The AERO Series features a number of multimedia display and storage solutions. They are all free standing, thus, eliminating the need for wood blocking in the walls, damage to finished walls, and misalignment of power and data connections. Each component uses a vertical convection riser to help vent media appliances, thus keeping them cool and functioning. Optional low profile credenzas increase the possible uses like public areas. Additionally an optional teleconference camera shelf can be specified in wood or glass.

#### – Flat Panel Mounting Site

The screen is not bound by wood casework. This offers flexibility for flat screen mounting, changing, and upgrading in the future.

#### – Optional End Details

Allows for bookcase attachment, possible private office placement. Bookcase optional glass shelf and halogen lighting.



## INNOVATIVE WIRE MANAGEMENT

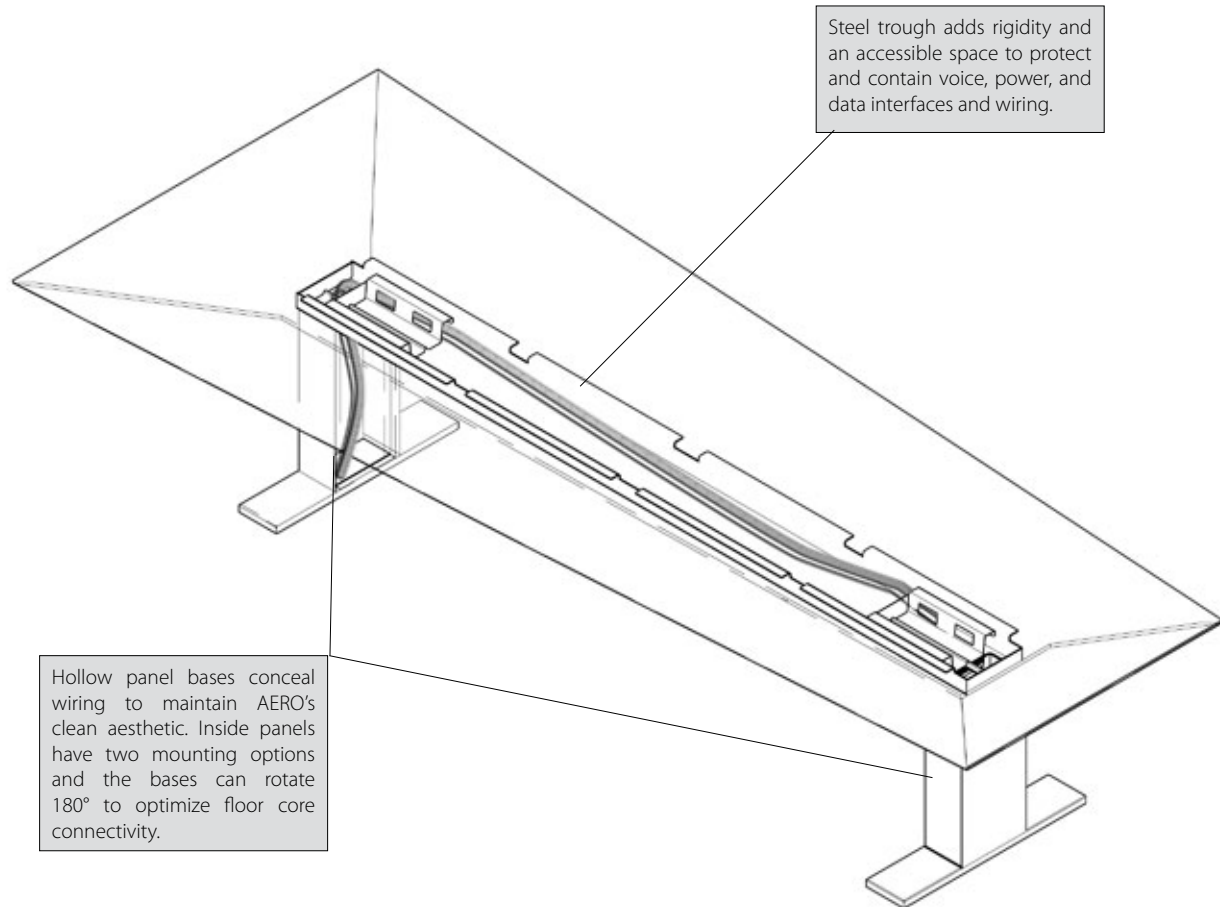

Each connection point on rectangular and video conferencing tables includes 2-power duplexes and 2-voice/data plates. Square tables 1-power duplex and 1-voice/data plate. Receptacles include flexible conduit so they may be daisy-chained together, or connected to an external power source. Hard wire options are available. Voice/Data plates are standard with 1-RJ11 and 1-RJ45. Contact factory for options.



conference  
tables



AERO Conference Tables feature a pedestal base and angular sub-top allowing the table to remain light in scale while optimizing strength and wire management. The pedestal bases and tops are finished with CCN’s beautifully selected and matched wood veneers while the sub-top is finished in our Mica Color Finishes to

blend or contrast. Pedestal bases are supported by metal feet available in polished stainless steel, powder coat aluminum, as well as, 4 additional powder coat finishes. Voice, power, and data offer superior connectivity, and beautiful matching wood doors.



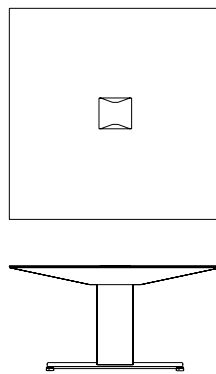
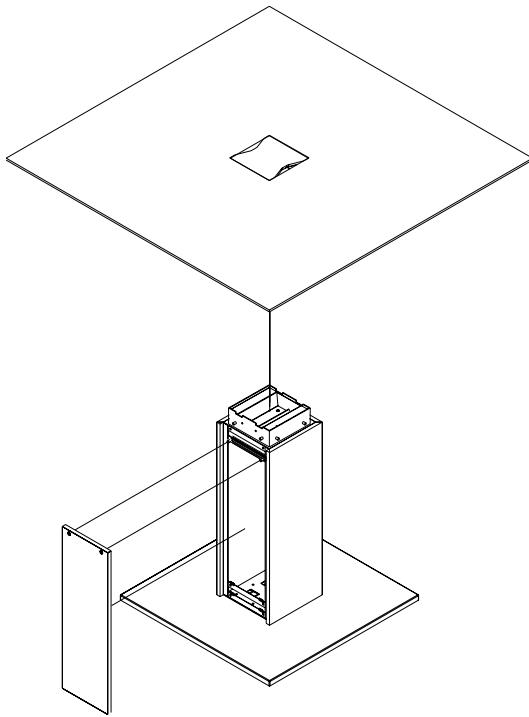

Description	Model *	D	W	H	Price (A)	Price (S)	Weight (lbs.)
<b>Square Conference Table</b> (1-piece top, 1-base, 1-VPD doors)							
	ATS1-4242-0-AD1	42"	42"	30"	\$5882	\$6071	210
	ATS1-4848-0-AD1	48"	48"	30"	\$6370	\$6559	238
	ATS1-5454-0-AD1	54"	54"	30"	\$6899	\$7209	274
	ATS1-6060-0-AD1	60"	60"	30"	\$7449	\$7759	310

\* Model number varies depending on metal finish selections.

■ - Will depend on your finish selection below.

A = Aluminum Powder Coat

S = Stainless Steel

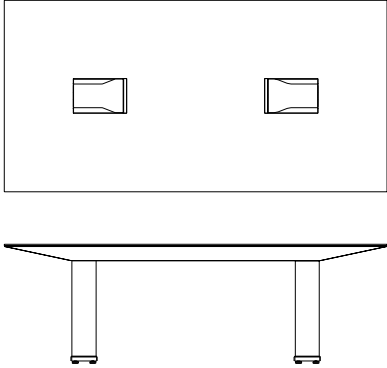
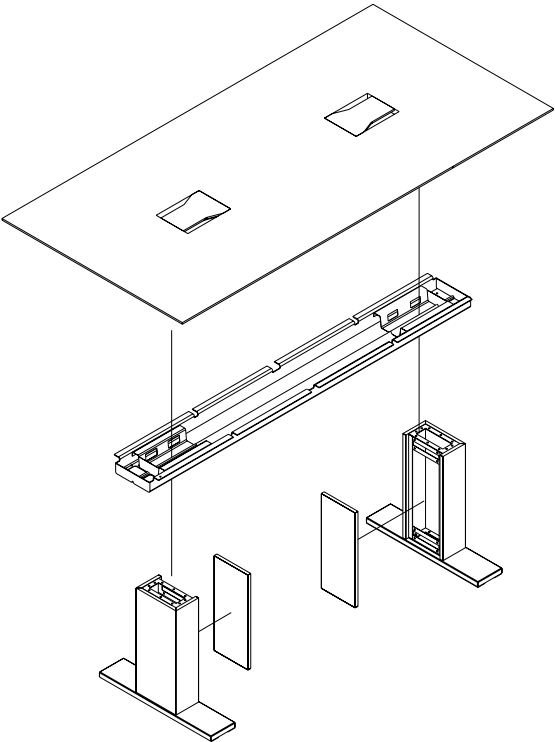

Description	Model *	D	W	H	Price (A)	Price (S)	Weight (lbs.)
<b>Rectangle Table I</b>							
(1-piece top, 2-bases, 2-VPD doors)	ATS2-4284-0-AD2	42"	84"	30"	\$10020	\$10344	306
	ATS2-4884-0-AD2	48"	84"	30"	\$10341	\$10665	332
	ATS2-5484-0-AD2	54"	84"	30"	\$10665	\$10989	359
	ATS2-4296-0-AD2	42"	96"	30"	\$10536	\$10860	338
	ATS2-4896-0-AD2	48"	96"	30"	\$10886	\$11210	368
	ATS2-5496-0-AD2	54"	96"	30"	\$11239	\$11563	398
	ATS2-42120-0-AD2	42"	120"	30"	\$11746	\$12070	404
	ATS2-48120-0-AD2	48"	120"	30"	\$12157	\$12481	441
	ATS2-54120-0-AD2	54"	120"	30"	\$12570	\$12894	479

\* Model number varies depending on metal finish selections.  
 ■ - Will depend on your finish selection below.  
 A = Aluminum Powder Coat  
 S = Stainless Steel



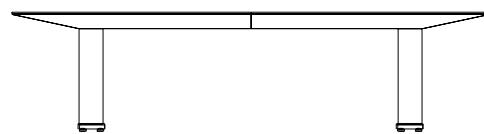
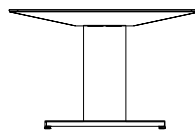
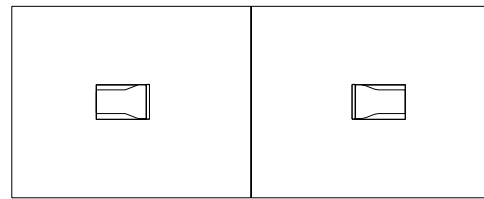
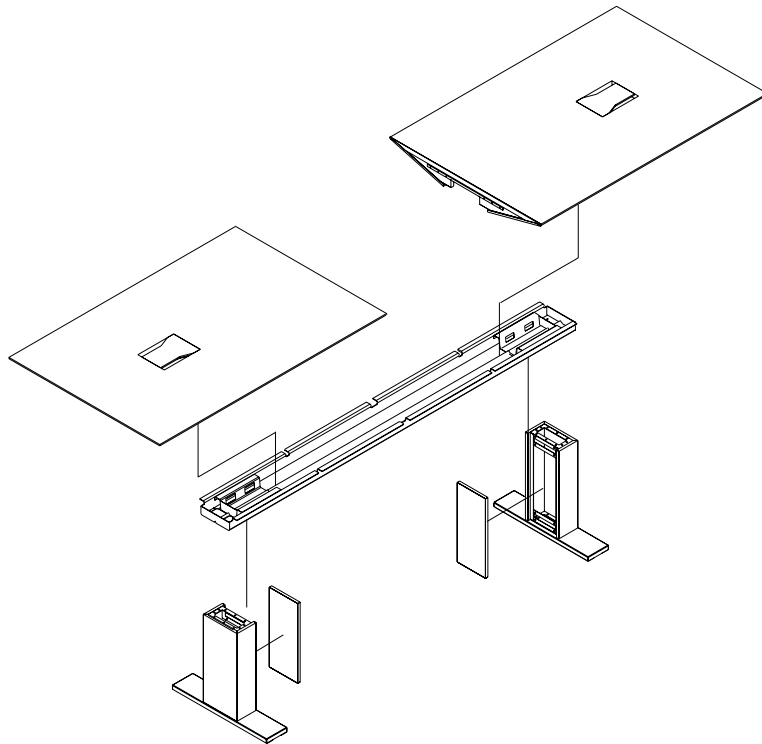

Description	Model *	D	W	H	Price (A)	Price (S)	Weight (lbs.)
-------------	---------	---	---	---	-----------	-----------	---------------

**Rectangle Table II**

(2-piece top, 2-bases, 2-VPD doors)

ATS2-48144-0-AD2      48"   144"   30"      \$13450   \$13774      515

ATS2-54144-0-AD2      54"   144"   30"      \$13928   \$14252      560

\* Model number varies depending on metal finish selections.

■ - Will depend on your finish selection below.

A = Aluminum Powder Coat

S = Stainless Steel



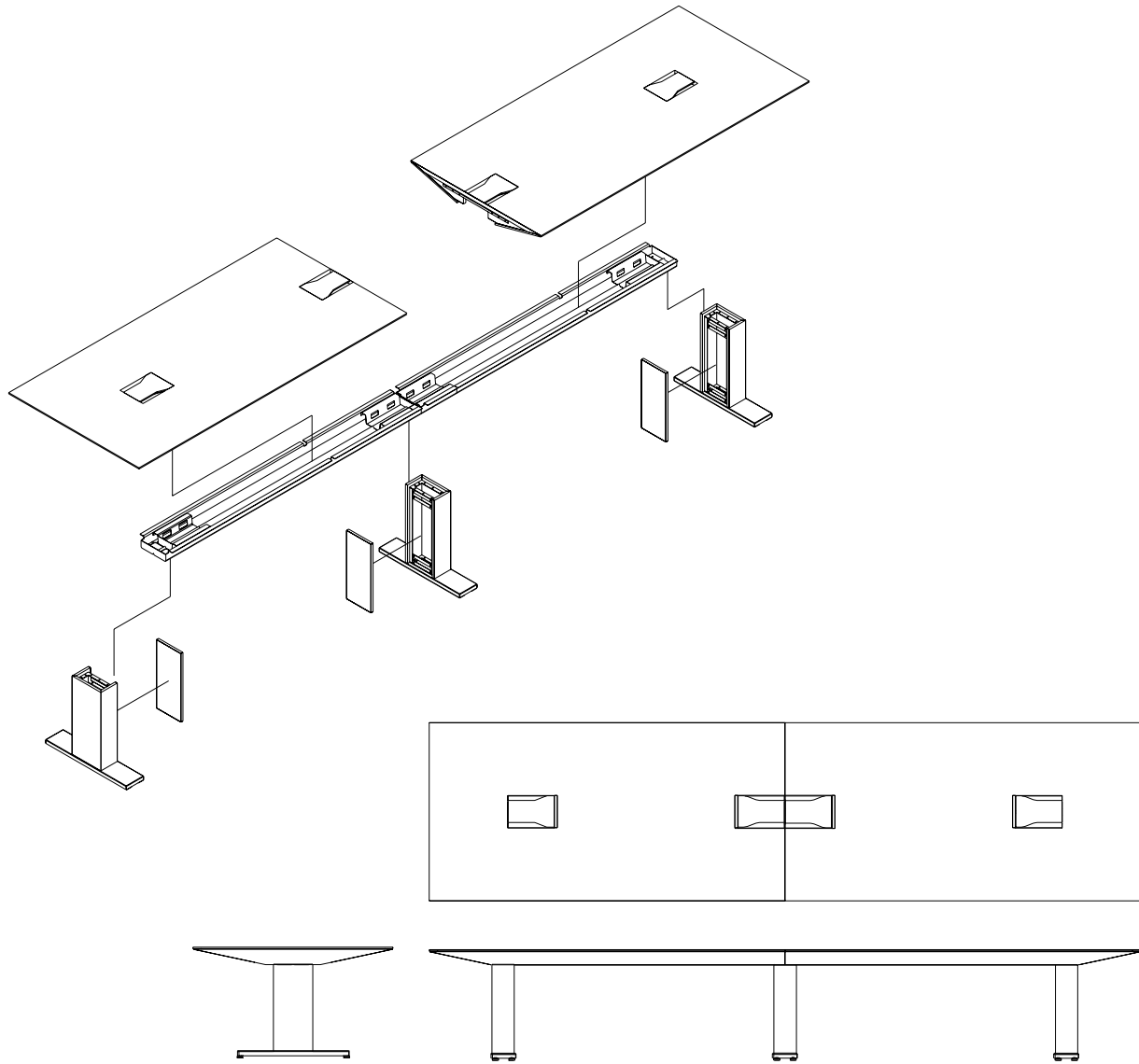

Description	Model *	D	W	H	Price (A)	Price (S)	Weight (lbs.)
<b>Rectangle Table IV</b>							
(2-piece top, 3-bases, 4-VPD doors)	ATS3-48192-0-AD4	48"	192"	30"	\$20275	\$20761	706
	ATS3-54192-0-AD4	54"	192"	30"	\$20911	\$21397	766
	ATS3-48216-0-AD4	48"	216"	30"	\$21595	\$22081	778
	ATS3-54216-0-AD4	54"	216"	30"	\$22311	\$22797	845

\* Model number varies depending on metal finish selections.  
 ■ - Will depend on your finish selection below.  
 A = Aluminum Powder Coat  
 S = Stainless Steel

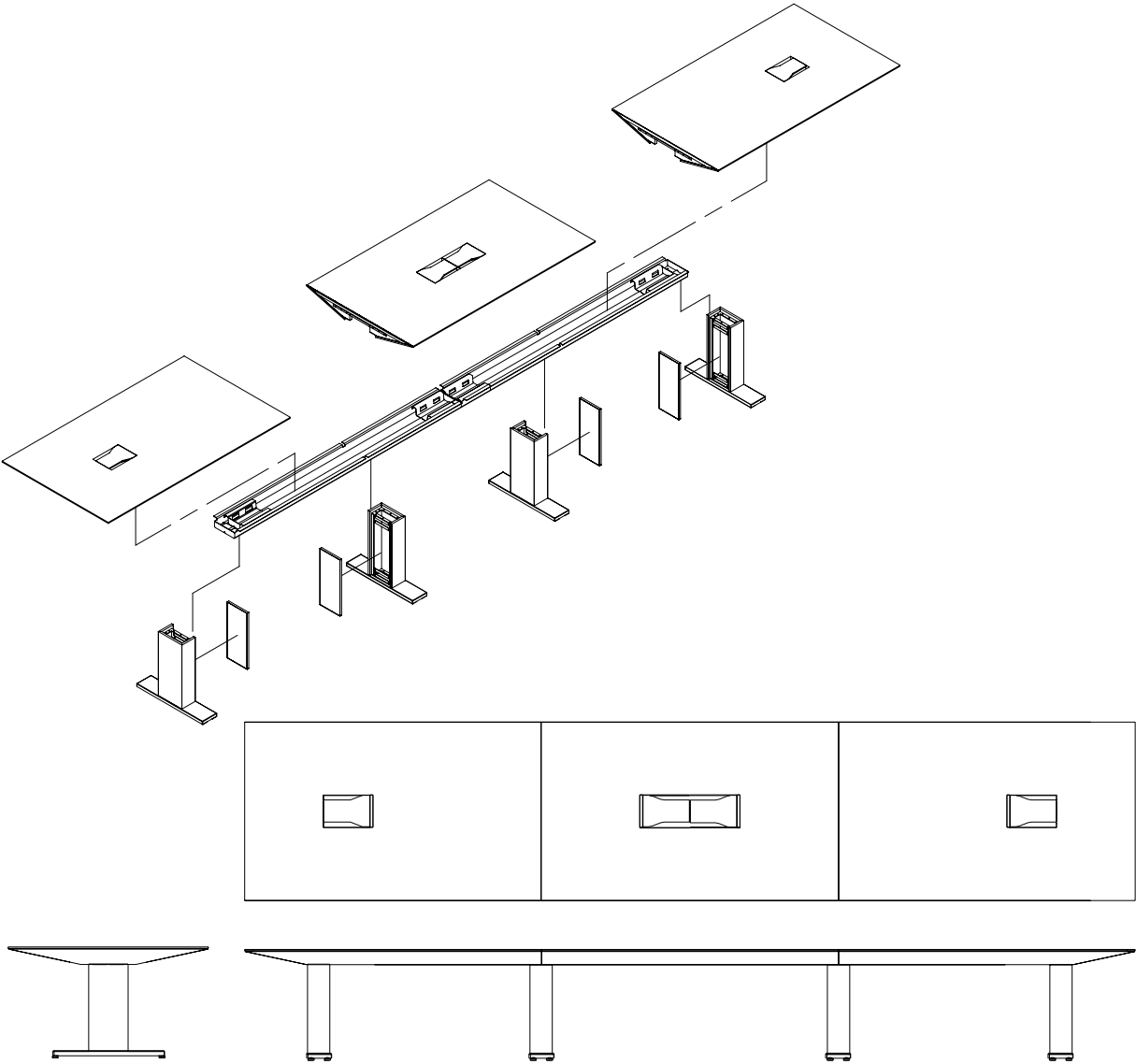

Description	Model *	D	W	H	Price (A)	Price (S)	Weight (lbs.)
Rectangle Table V (3-piece top, 4-bases, 4-VPD doors)	ATS4-48240-0-AD4	48"	240"	30"	\$24613	\$25261	896
	ATS4-54240-0-AD4	54"	240"	30"	\$25407	\$26055	971

\* Model number varies depending on metal finish selections.  
 ■ - Will depend on your finish selection below.  
 A = Aluminum Powder Coat  
 S = Stainless Steel



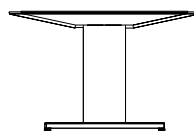
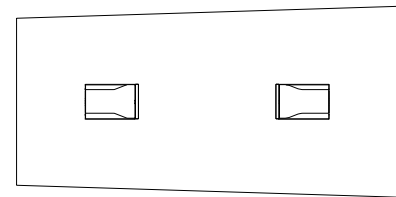
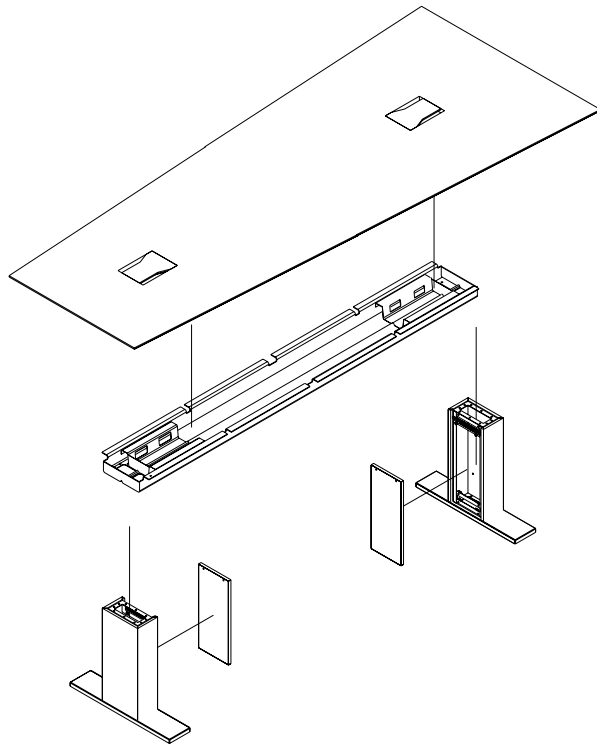

Description	Model *	D	W	H	Price (A)	Price (S)	Weight (lbs.)
-------------	---------	---	---	---	-----------	-----------	---------------

**Video Conferencing Table I**  
 (1-piece top, 2-bases, 2-VPD doors)

ATW2-5496-0-AD2	42/54"	96"	30"	\$12132	\$12456	378
-----------------	--------	-----	-----	---------	---------	-----

ATW2-54120-0-AD2	42/54"	120"	30"	\$13683	\$14007	454
------------------	--------	------	-----	---------	---------	-----

\* Model number varies depending on metal finish selections.

■ - Will depend on your finish selection below.

A = Aluminum Powder Coat

S = Stainless Steel

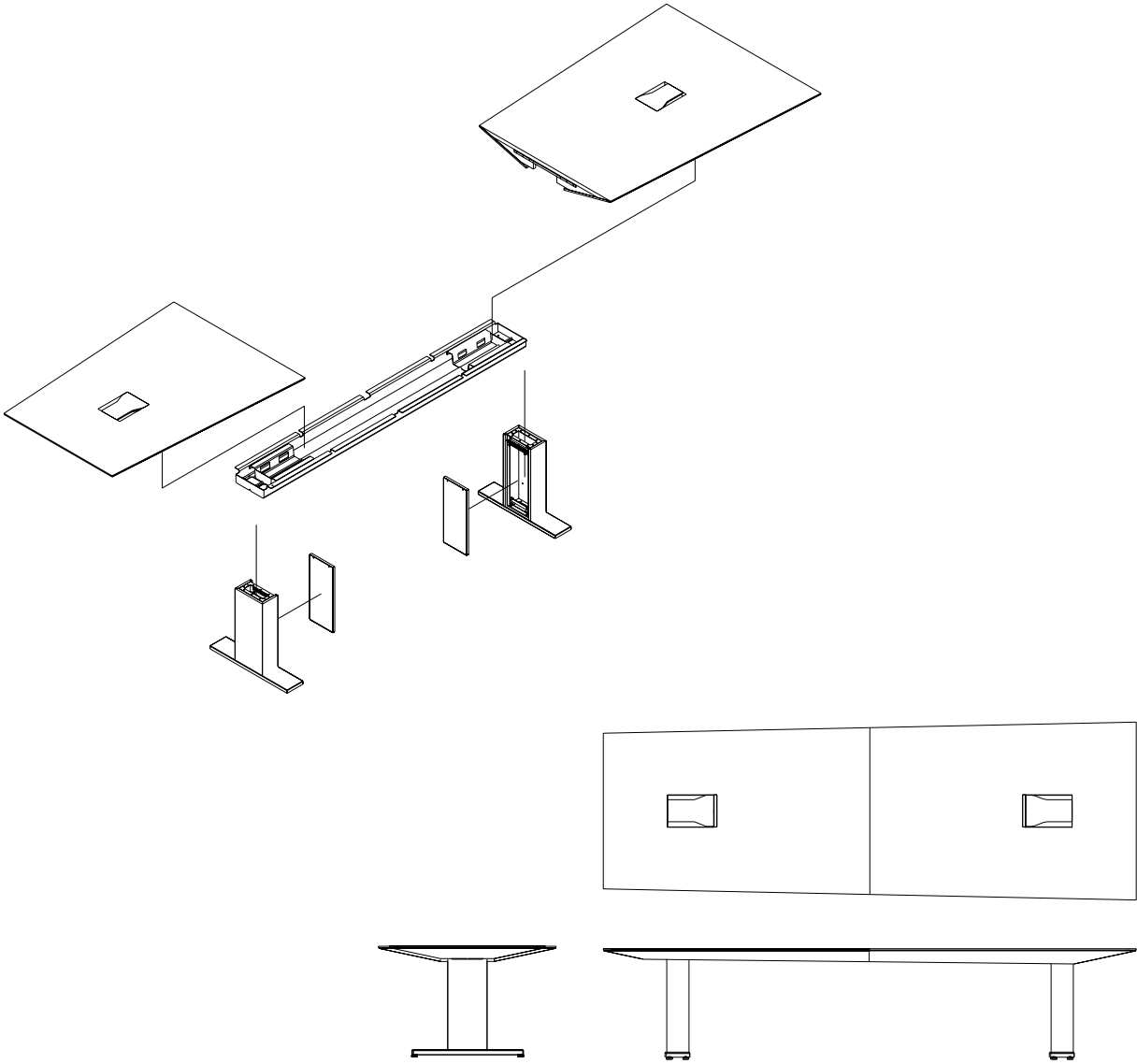

Description	Model *	D	W	H	Price (A)	Price (S)	Weight (lbs.)
Video Conferencing Table II (2-piece top, 2-bases, 2-VPD doors)	ATW2-54144-0-AD2	42/54"	144"	30"	\$15267	\$15591	530

\* Model number varies depending on metal finish selections.  
 - Will depend on your finish selection below.  
 A = Aluminum Powder Coat  
 S = Stainless Steel



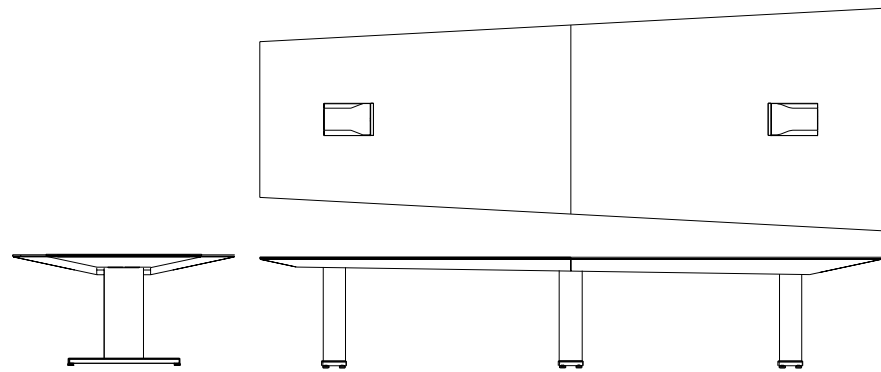
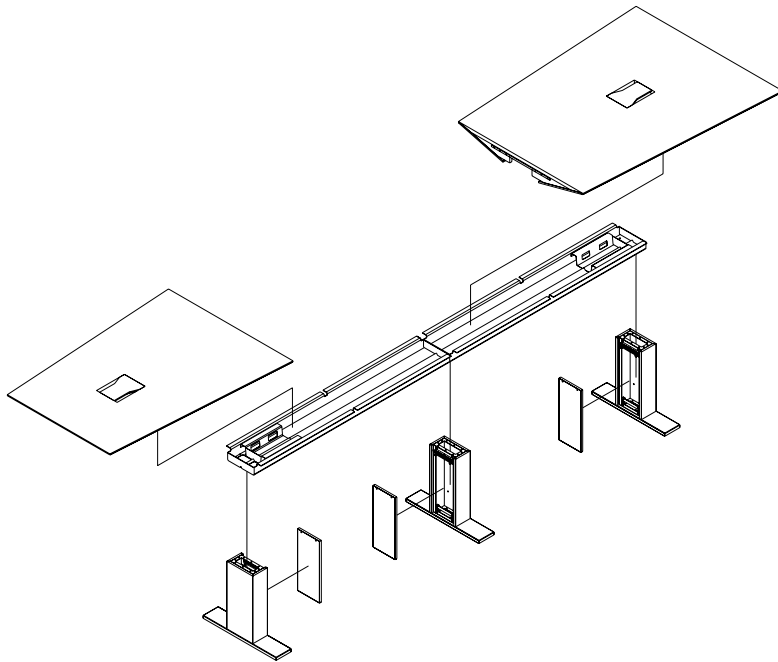

Description	Model *	D	W	H	Price (A)	Price (S)	Weight (lbs.)
Video Conferencing Table III (2-piece top, 3-bases, 2-VPD doors)	ATW3-60168-0-AD2	42/60"	168"	30"	\$19850	\$20336	704

\* Model number varies depending on metal finish selections.  
 - Will depend on your finish selection below.  
 A = Aluminum Powder Coat  
 S = Stainless Steel

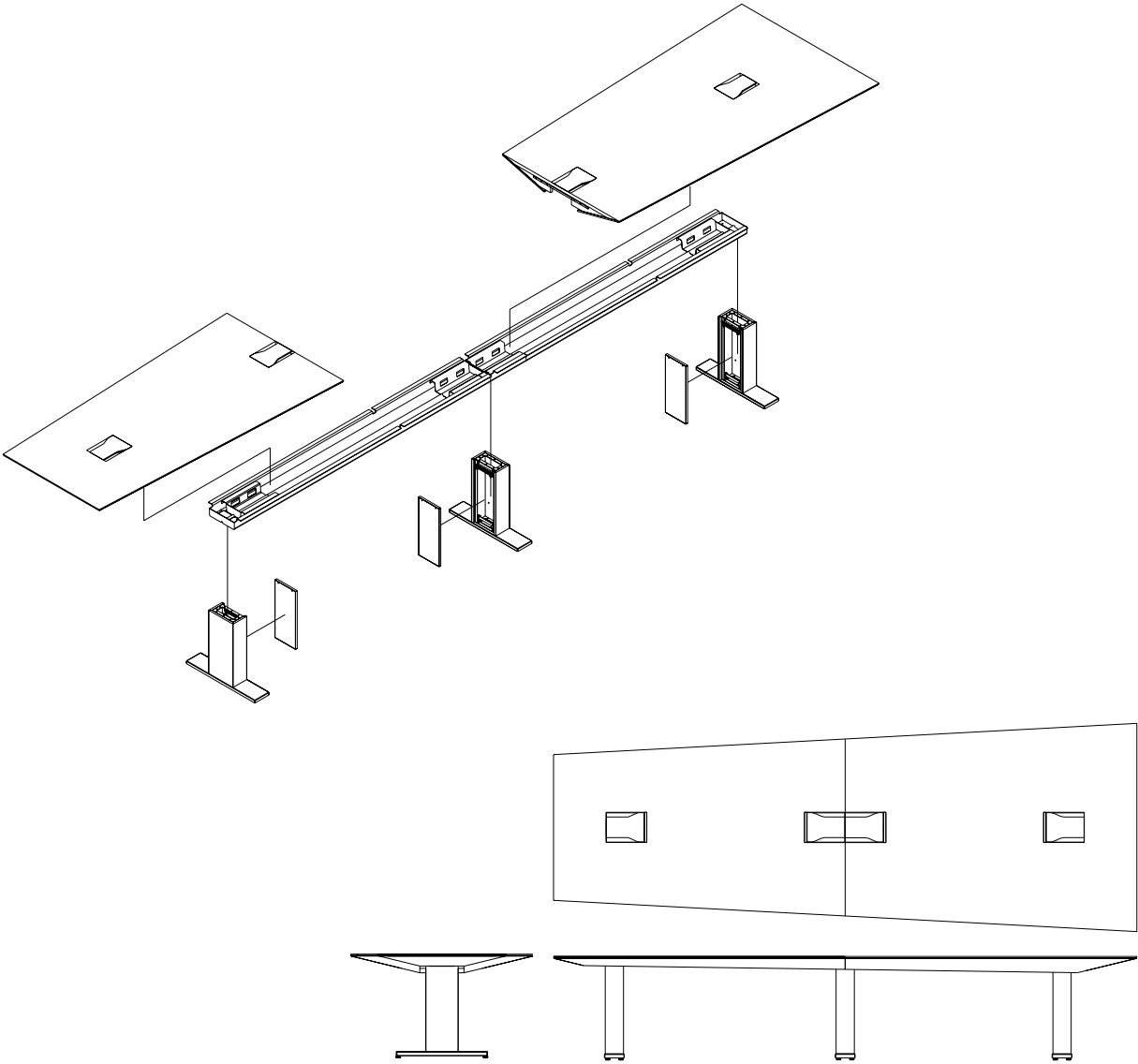

Description	Model *	D	W	H	Price (A)	Price (S)	Weight (lbs.)
Video Conference Table IV (2-piece top, 3-bases, 4-VPD doors)	ATW3-60192-0-AD4	42/60"	192"	30"	\$23337	\$23823	786

\* Model number varies depending on metal finish selections.  
 - Will depend on your finish selection below.  
 A = Aluminum Powder Coat  
 S = Stainless Steel







media  
units

Media Units are available with two credenza heights. The 36" buffet height is the perfect compliment to a conference table. The 20" high credenza is ideal for use in public areas, or other stand alone situations. They make a strong statement with clean lines and angular

details. Media Units are available with outer bookcase ends providing ample storage and an optional video-conferencing camera shelf.

See page 28 for all optional details.

All units shown with optional camera shelf.  
See page 28 for additional options.



Description	Model *	D	W	H	Price (A)	Price (S)	Weight
 <p><b>Media Unit I</b> (with 36" buffet height credenza)</p>	AVDC4S-246086-HiH	24"	60"	85½"	\$10230	\$10566	336
 <p><b>Media Unit II</b> (with 36" buffet height credenza)</p>	AVDC4S-247286-GGGG	24"	72"	85½"	\$10411	\$10808	378
	AVDC4S-248486-GGGG	24"	84"	85½"	\$10672	\$11080	410
 <p><b>Media Unit III</b> (with end bookcases)</p>	AVDX40-2410686-HiH	24"	106"	85½"	\$18126	\$19016	760
 <p><b>Media Unit IV</b> (with end bookcases)</p>	AVDX40-2411886-GGGG	24"	118"	85½"	\$18306	\$19254	802
	AVDX40-2413086-GGGG	24"	130"	85½"	\$18574	\$19532	835

\* Model number varies depending on metal finish selections.

■ - Will depend on your finish selection below.

A = Aluminum Powder Coat

S = Stainless Steel

All units shown with optional camera shelf.  
See page 28 for additional options.

Description	Model *	D	W	H	Price (A)	Price (S)	Weight
 <p><b>Media Unit V</b> (with 20" H Credenza)</p>	AVDC1S-187274-HHHH	18"	72"	74"	\$9379	\$9733	369
 <p><b>Media Unit VI</b> (with 20" H Credenza)</p>	AVDC1S-188474-HHHH	18"	84"	74"	\$9643	\$10008	400
 <p><b>Media Unit VII</b> (with end bookcases)</p>	AVDX10-1811874-HHHH	18"	118"	74"	\$15940	\$16834	667
 <p><b>Media Unit VIII</b> (with end bookcases)</p>	AVDX10-1813074-HHHH	18"	130"	74"	\$16205	\$17107	698

\* Model number varies depending on metal finish selections.  
 ■ - Will depend on your finish selection below.  
 A = Aluminum Powder Coat  
 S = Stainless Steel

All units shown with optional camera shelf.  
 See page 28 for additional options.



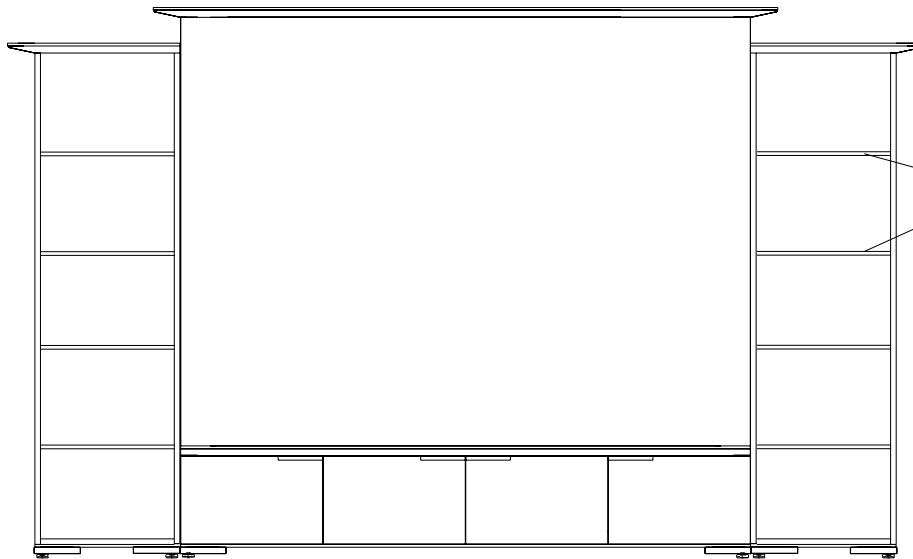

Media Units come standard with wood shelves. Optional glass shelves and halogen light package may be specified. Optional hinged doors are also available for the end bookcases.

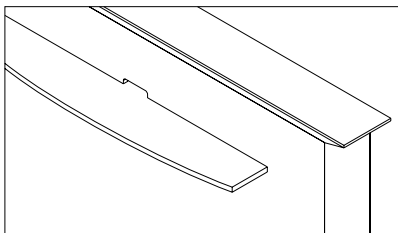

Radiused 3/4" tempered glass camera shelf.

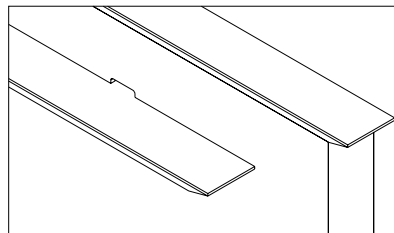

Wood camera shelf.

AERO Optional Details	Model	D	W	H	Price
Wood Camera Shelf	AACSW	8"	45"	1 3/8"	\$450
Glass Camera Shelf	AACSG	8"	45"	3/4"	\$1000
Glass & Light Package I (for 66" H unit. Price reflects both sides)	AAGP1			66"	\$1150
Glass & Light Package II (for 77 1/2" H unit. Price reflects both sides)	AAGP2			77 1/2"	\$1150
Bookend Doors I (for 66" H unit. Price reflects both sides)	AABD1	3/4"	20"	66"	\$1000
Bookend Doors II (for 77 1/2" H unit. Price reflects both sides)	AABD2	3/4"	20"	77 1/2"	\$1090

All units shown with optional camera shelf. See page 28 for additional options.







buffet  
credenza



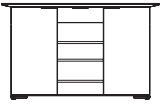

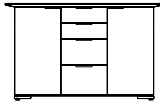
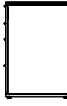

AERO Buffet Credenzas feature a similar aesthetic as the tables. The DuoTone finish adds a floating quality to the top and the enhances the light scale. The top is flush

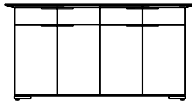
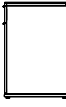
along the case front with angular details overhanging on the sides. A metal reveal accents the bottom of the case.

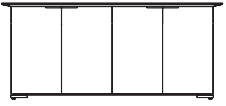
Description	Model *	D	W	H	Price (A)	Price (S)	Weight
   	AC0V00-246036-HiH	24"	60"	36"	\$5870	\$6206	190
	AC0V00-246036-HcH	24"	60"	36"	\$6271	\$6629	220

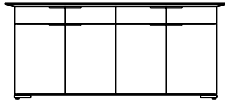
   	AC0V00-247236-HHHH	24"	72"	36"	\$5387	\$5746	204
	AC0V00-247236-GGGG	24"	72"	36"	\$5972	\$6370	214

   	AC0V00-248436-HHHH	24"	84"	36"	\$5570	\$5940	218
	AC0V00-248436-GGGG	24"	84"	36"	\$6156	\$6564	228

     	AC0V00-249636-GGGGGG	24"	96"	36"	\$7712	\$8168	262
	AC0V00-249636-GGtGG	24"	96"	36"	\$8968	\$9396	372
	AC0V00-249636-GGjGG	24"	96"	36"	\$8371	\$8799	342

\* Model number varies depending on metal finish selections.

■ - Will depend on your finish selection below.

A = Aluminum Powder Coat

S = Stainless Steel



The AERO collection includes various complimentary items to complete any conference room. The Lectern features an angular sub-top, pedestal and accent base that compliments the table. The Serving Carts provide convenient, portable storage with an integral handle built in the top end overhangs. Visual Boards are

available with or without hinged doors. Dry erase boards are included on the door backs to extend the writing surface area when fully opened. Hospitality Tables and Bookcases add a functional finishing touch that matches the AERO aesthetic and ties the room together with a strong design statement.

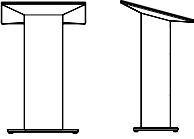
Description	Model *	D	W	H	Price (A)	Price (S)	Weight
							
Hospitality Cart	AVSNC1-204636	20"	46"	36"	\$4210	\$4312	158
	AVSHC1-204636	20"	46"	36"	\$4791	\$4913	178
							
Hospitality Table	ATS4L-216036-JJJ	21"	60"	36"	\$5999	\$5999	134
	ATS4L-217236-JJJJ	21"	72"	36"	\$6860	\$6860	162
							
Lectern	AVP000-293248	29"	32"	48"	\$3782	\$3971	100
							
White Media Board A	AVBN-48485	48"	48"	4½"	\$2093	\$2093	100
	AVBN-54485	54"	48"	4½"	\$2221	\$2221	113
	AVBN-60485	60"	48"	4½"	\$2349	\$2349	125
	AVBN-72485	72"	48"	4½"	\$2608	\$2608	150
	AVBN-96485	96"	48"	4½"	\$3122	\$3122	200
White Media Board B (with cabinet enclosure)	AVBH00-48486	48"	48"	6"	\$3292	\$3311	172
	AVBH00-54486	54"	48"	6"	\$3679	\$3698	194
	AVBH00-60486	60"	48"	6"	\$3862	\$3881	215

\* Model number varies depending on metal finish selections.

■ - Will depend on your finish selection below.

A = Aluminum Powder Coat

S = Stainless Steel

Description	Model *	D	W	H	Price (A)	Price (S)	Weight
	ASBU11-1530	15"	30"	30"	\$2183	\$2456	78
	ASBU11-1536	15"	36"	30"	\$2307	\$2585	90

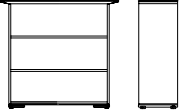
	ASBU12-153042	15"	30"	42"	\$2561	\$2833	103
	ASBU12-153642	15"	36"	42"	\$2705	\$2981	118

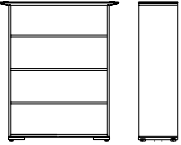
	ASBU13-153054	15"	30"	54"	\$2940	\$3210	127
	ASBU13-153654	15"	36"	54"	\$3101	\$3380	146

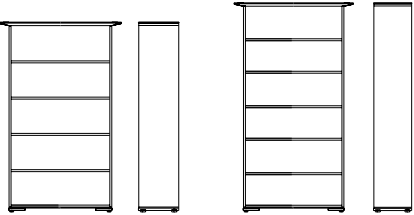

	ASBU14-153072	15"	30"	72"	\$3361	\$3633	159
	ASBU14-153672	15"	36"	72"	\$3543	\$3821	182
	ASBU15-153084	15"	30"	84"	\$3738	\$4010	183
	ASBU15-153684	15"	36"	84"	\$3942	\$4220	209

\* Model number varies depending on metal finish selections.

■ - Will depend on your finish selection below.

A = Aluminum Powder Coat

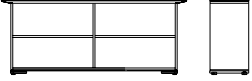
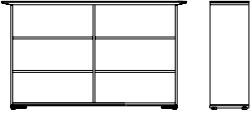
S = Stainless Steel

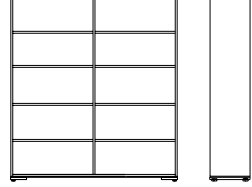
Description	Model *	D	W	H	Price (A)	Price (S)	Weight
 Dual Bay Bookcase I	ASBU21■-1560	15"	60"	30"	\$3622	\$4016	147
	ASBU21■-1572	15"	72"	30"	\$3884	\$4292	171
 Dual Bay Bookcase II	ASBU22■-156042	15"	60"	42"	\$4352	\$4746	192
	ASBU22■-157242	15"	72"	42"	\$4654	\$5059	222
 Dual Bay Bookcase III	ASBU23■-156054	15"	60"	54"	\$5082	\$5476	237
	ASBU23■-157254	15"	72"	54"	\$5422	\$5827	274
 Dual Bay Bookcase IV	ASBU24■-156072	15"	60"	72"	\$5885	\$6279	295
	ASBU24■-157272	15"	72"	72"	\$6268	\$6673	341

\* Model number varies depending on metal finish selections.

■ - Will depend on your finish selection below.

A = Aluminum Powder Coat

S = Stainless Steel



CCN International manufactures high-quality, upscale office furniture for management, executive, conference and reception areas. We are known for our level of detail, our flexibility and our shared appreciation for the beauty and warmth of wood furniture. This philosophy is evident throughout our product line, ranging from traditional to contemporary to artisan style office furniture. For more information visit [www.ccintl.com](http://www.ccintl.com).



CCN International Inc.  
200 Lehigh Street  
Geneva, New York 14456  
315-789-4400  
[www.ccintl.com](http://www.ccintl.com)



Printed on paper certified by the  
Forest Stewardship Council

**100%**  
From well-managed forests